

LM25010 Evaluation Board

National Semiconductor
Application Note 1431
Dennis Morgan
December 2005



Introduction

The LM25010EVAL evaluation board provides the design engineer with a fully functional buck regulator, employing the constant on-time (COT) operating principle. This evaluation board provides a 5V output over an input range of 6V - 42V. The circuit delivers load currents to 1A, with current limit set at $\approx 1.3A$. The board is populated with all external components except R6 and C9-C11. These components provide options for reducing output ripple as described later in this document.

The board's specification are:

- Input Voltage: 6V to 42V
- Output Voltage: 5V
- Maximum load current: 1.0A
- Minimum load current: 0A
- Current Limit: 1.3A
- Measured Efficiency: 95.5% ($V_{IN} = 6V$, $I_{OUT} = 200\text{ mA}$)
- Nominal Switching Frequency: 200 kHz
- Size: 2.25 in. x 0.88 in. x 0.47 in

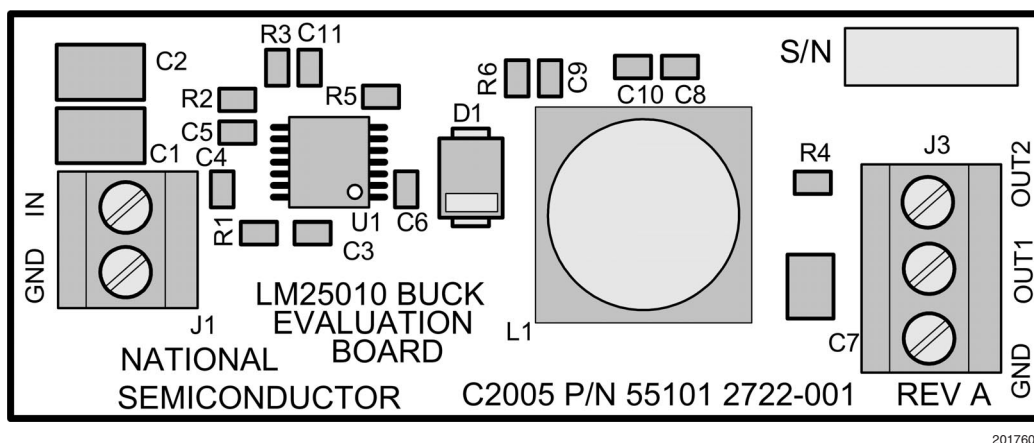

FIGURE 1. Evaluation Board - Top Side

Theory of Operation

Refer to the evaluation board schematic in Figure 3, which contains a simplified block diagram of the LM25010. When the circuit is in regulation, the buck switch is on each cycle for a time determined by R1 and V_{IN} according to the equation:

$$t_{ON} = \frac{1.18 \times 10^{-10} \times (R1 + 1.4k)}{(V_{IN} - 1.4V)} + 67\text{ ns}$$

The on-time of this evaluation board ranges from $\approx 5000\text{ ns}$ at $V_{IN} = 6V$, to $\approx 650\text{ ns}$ at $V_{IN} = 42V$. The on-time varies inversely with V_{IN} to maintain a nearly constant switching frequency. At the end of each on-time the Minimum Off-Timer ensures the buck switch is off for at least 260 ns. In normal operation, the off-time is much longer. During the off-time, the output capacitor (C7) is discharged by the load current. When the output voltage falls sufficiently that the voltage at FB is below 2.5V, the regulation comparator initiates a new on-time period. For stable, fixed frequency operation, $\approx 25\text{ mV}$ of ripple is required at FB to switch the regulation comparator. Refer to the LM25010 data sheet for a more detailed block diagram, and a complete description of the various functional blocks.

Board Layout and Probing

The pictorial in Figure 1 shows the placement of the circuit components. The following should be kept in mind when the board is powered:

- 1) When operating at high input voltage and high load current, forced air flow is necessary.
- 2) The LM25010, and the diode D1 will be hot to the touch when operating at high input voltage and high load current.
- 3) Use CAUTION when probing the circuit at high input voltages to prevent injury, as well as possible damage to the circuit.
- 4) At maximum load current (1A), the wire size and length used to connect the load becomes important. Ensure there is not a significant drop in the wires between this evaluation board and the load.

Board Connection/Start-up

The input connections are made to the J1 connector. The load is normally connected to the OUT1 and GND terminals of the J3 connector. Ensure the wires are adequately sized for the intended load current. Before start-up a voltmeter should be connected to the input terminals, and to the output terminals. The load current should be monitored with an

Board Connection/Start-up (Continued)

ammeter or a current probe. It is recommended that the input voltage be increased gradually to 6V, at which time the output voltage should be 5V. If the output voltage is correct with 6V at V_{IN} , then increase the input voltage as desired and proceed with evaluating the circuit.

Reducing Output Ripple

The LM25010 requires a minimum of 25 mVp-p ripple at the FB pin, in phase with the switching waveform at the SW pin, for proper operation. In the basic application circuit shown in the data sheet, C8 is not included. The required ripple at FB is derived from the ripple at V_{OUT1} , which is generated by the inductor's ripple current passing through R4 and the ESR of capacitor C7. Since the ripple voltage at V_{OUT1} is attenuated by the R2/R3 feedback divider, a minimum of 50 mVp-p is required at V_{OUT1} . If this ripple level is acceptable for the intended application, C8 can be removed from this evaluation board, and R4 increased to 1.5Ω. In that case, the minimum ripple amplitude (≈ 55 mVp-p) occurs at minimum V_{IN} (6V), and increases to ≈ 300 mVp-p at $V_{IN} = 42V$, as shown in Figure 6.

If a low ripple output is desired three alternatives are described below.

A) Ripple Reduction Option A: This EVB is supplied with C8 installed, and $R4 = 0.68\Omega$, providing a relatively low ripple output at V_{OUT1} since C8 couples the output ripple directly to FB without attenuation. The ripple amplitude at V_{OUT1} ranges from 30mVp-p to 150 mVp-p (see Figure 6) as V_{IN} is varied over its range. The minimum value for C8 is calculated from:

$$C8 = \frac{t_{ON(max)}}{(R2//R3)}$$

where $t_{ON(max)}$ is the maximum on-time at minimum V_{IN} , and $R2//R3$ is the equivalent parallel value of R2 and R3. For this

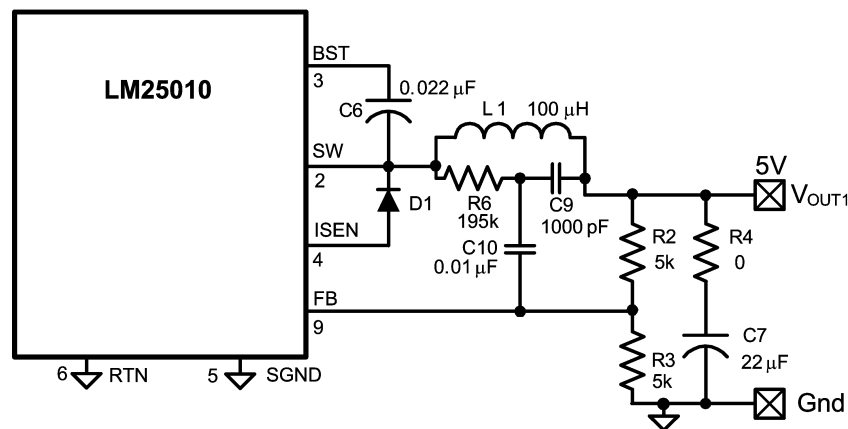

FIGURE 2. Low Ripple Output Using R6, C9, C10

The resulting ripple at V_{OUT1} ranges from 3 mVp-p at $V_{IN} = 6V$, to 11 mVp-p at $V_{IN} = 42V$, and varies slightly with load current. See Figure 6. These values are valid only for continuous conduction mode (load current is between 120 mA

evaluation board, $t_{ON(max)}$ is approximately 5000 ns, and $R2//R3 = 2.5k\Omega$, resulting in a minimum value of 0.002 μF for C8.

B) Ripple Reduction Option B: Add R6, C9, C10, replace R4 with zero ohms, and leave C8 and C11 positions open. Since the SW pin switches from -1V to V_{IN} , and the right end of C9 is a virtual ground, R6 and C9 are chosen to generate a 30-40 mVp-p triangle wave at their junction. That triangle wave is coupled to the FB pin through C10. To calculate the values for R6, C9, and C10, use the following procedure, using the minimum input voltage for V_{IN} :

Calculate the voltage V_A :

$$V_A = V_{OUT} - (V_{SW} \times (1 - (V_{OUT}/V_{IN})))$$

where V_{SW} is the absolute value of the voltage at the SW pin during the off-time (typically 1V), and V_{IN} is the minimum input voltage. For this circuit, V_A calculates to 4.83V. This is the DC voltage at the R6/C9 junction, and is used in the next equation.

Calculate the $R6 \cdot C9$ product:

$$R6 \cdot C9 = \frac{(V_{IN} - V_A) \times t_{ON}}{\Delta V}$$

where t_{ON} is the on-time at minimum V_{IN} ($\approx 5 \mu s$), and ΔV is the desired ripple amplitude at the R6/C9 junction, 30mV for this example.

$$R6 \cdot C9 = \frac{(6V - 4.83V) \times 5 \mu s}{0.03V} = 1.95 \times 10^{-4}$$

R6 and C9 are then chosen from standard value components to satisfy the above product. For example, C9 can be 1000 pF, requiring R6 to be 195 kΩ. C10 is chosen to be 0.01 μF , large compared to C9. The resulting circuit is:

Reducing Output Ripple (Continued)

the V_{OUT1} ripple ranges from ≈ 40 mVp-p to ≈ 120 mVp-p. If the circuit is operated in current limit mode the ripple ranges from ≈ 100 mVp-p to ≈ 300 mVp-p.

B) **Ripple Reduction Option C:** Connect the load to V_{OUT2} (leave R4 in). The ripple at this output varies from ≈ 3 mVp-p to ≈ 10 mVp-p over the input voltage range. See Figure 6. However, the load regulation is not as good at V_{OUT2} as at V_{OUT1} due to the presence of R4. This alternative may be preferred for applications where the load current is relatively constant.

Increasing the Current Limit

The evaluation board current limit activates at a load current of ≈ 1.3 A. If it is desired to increase the current limit for a

particular application, R5 must be added to the board. Refer to the LM25010 data sheet to determine the appropriate value for this resistor.

Minimum Load Current

The LM25010 requires a minimum load current of ≈ 500 μ A to ensure the boost capacitor (C6) is recharged sufficiently during each off-time. In this evaluation board, the minimum load current is provided by the feedback resistor (R2, R3), allowing the board's minimum load current at V_{OUT1} (or V_{OUT2}) to be specified at zero.

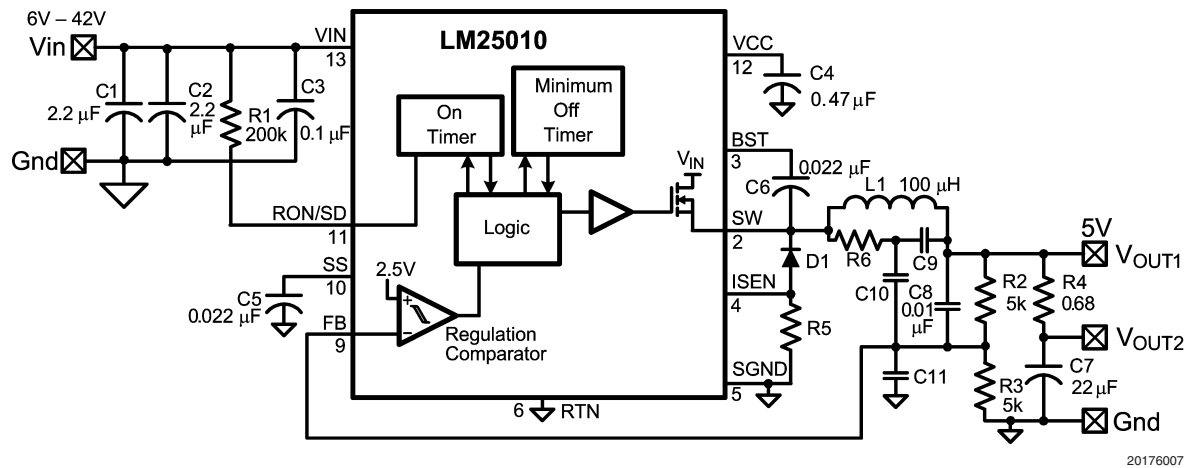
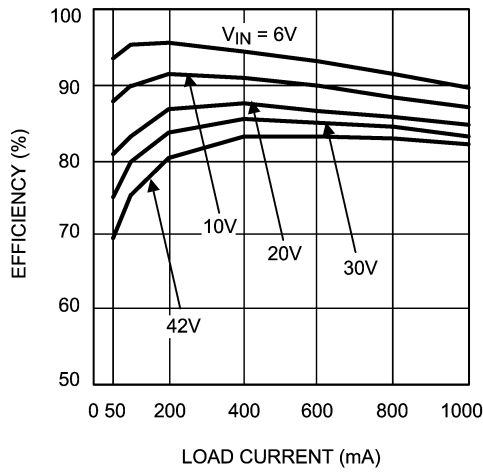

FIGURE 3. Evaluation Board Schematic

Bill of Materials

| Item | Description | Mfg., Part Number | Package | Value |
|-------|---------------------|--|-------------------|--------------------|
| C1, 2 | Ceramic Capacitor | TDK C3225X7R1H225M | 1210 | 2.2 μ F, 50V |
| C3 | Ceramic Capacitor | TDK C2012X7R2A104M | 0805 | 0.1 μ F, 100V |
| C4 | Ceramic Capacitor | TDK C2012X7R1C474M | 0805 | 0.47 μ F, 16V |
| C5, 6 | Ceramic Capacitor | TDK C2012X7R1C223M | 0805 | 0.022 μ F, 16V |
| C7 | Ceramic Capacitor | TDK C3225X7R1C226M | 1210 | 22 μ F, 16V |
| C8 | Ceramic Capacitor | TDK C2012X7R1C103M | 0805 | 0.01 μ F, 16V |
| C9 | | Unpopulated | | |
| C10 | | Unpopulated | | |
| C11 | | Unpopulated | | |
| D1 | Schottky Diode | Central Semi DFSL160 | Power DI123 | 60V,1A |
| L1 | Power Inductor | TDK SLF12575T-101M1R9, or Cooper Bussmann DR125-101 | 12.5 mm x 12.5 mm | 100 μ H, 1.9A |
| R1 | Resistor | CRCW08052003F | 0805 | 200 k Ω |
| R2, 3 | Resistor | CRCW08054991F | 0805 | 4.99 k Ω |
| R4 | Resistor | ERJ-6RQFR68V (Panasonic) | 0805 | 0.68 Ω |
| R5 | | Unpopulated | | |
| R6 | | Unpopulated | | |
| U1 | Switching Regulator | National Semiconductor LM25010MH | TSSOP - 14EP | |



20176008

FIGURE 4. Efficiency vs Load Current

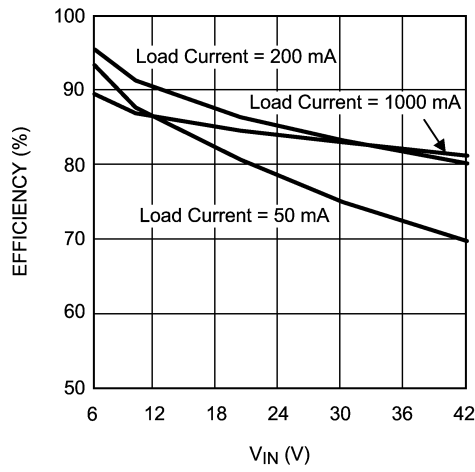

20176009

FIGURE 5. Efficiency vs V_{IN}

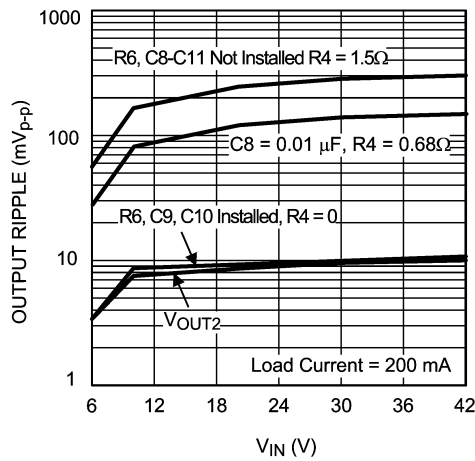

20176010

FIGURE 6. Voltage Ripple at V_{OUT1} , V_{OUT2}

PCB Layout

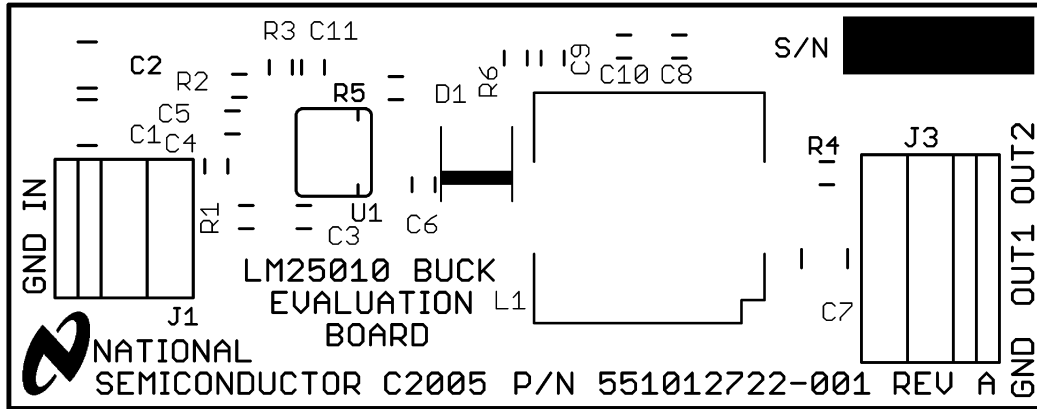

Board Silkscreen

20176011

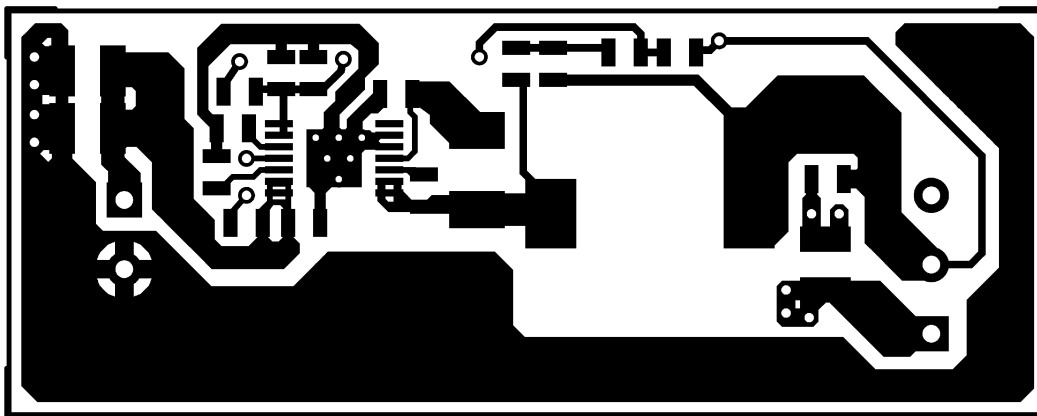

Board Top Layer

20176012

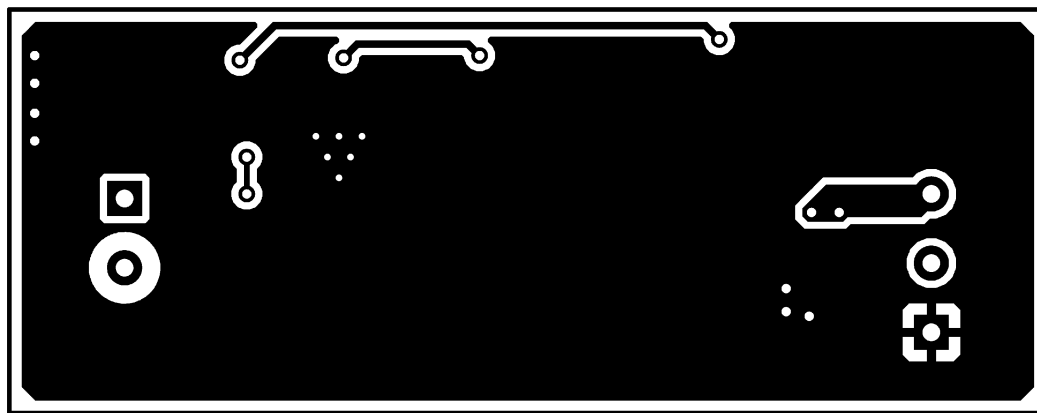

Board Bottom Layer (viewed from top)

20176013

Notes

National does not assume any responsibility for use of any circuitry described, no circuit patent licenses are implied and National reserves the right at any time without notice to change said circuitry and specifications.

For the most current product information visit us at www.national.com.

LIFE SUPPORT POLICY

NATIONAL'S PRODUCTS ARE NOT AUTHORIZED FOR USE AS CRITICAL COMPONENTS IN LIFE SUPPORT DEVICES OR SYSTEMS WITHOUT THE EXPRESS WRITTEN APPROVAL OF THE PRESIDENT AND GENERAL COUNSEL OF NATIONAL SEMICONDUCTOR CORPORATION. As used herein:

1. Life support devices or systems are devices or systems which, (a) are intended for surgical implant into the body, or (b) support or sustain life, and whose failure to perform when properly used in accordance with instructions for use provided in the labeling, can be reasonably expected to result in a significant injury to the user.
2. A critical component is any component of a life support device or system whose failure to perform can be reasonably expected to cause the failure of the life support device or system, or to affect its safety or effectiveness.

BANNED SUBSTANCE COMPLIANCE

National Semiconductor manufactures products and uses packing materials that meet the provisions of the Customer Products Stewardship Specification (CSP-9-111C2) and the Banned Substances and Materials of Interest Specification (CSP-9-111S2) and contain no "Banned Substances" as defined in CSP-9-111S2.

Leadfree products are RoHS compliant.



National Semiconductor
Americas Customer
Support Center
Email: new.feedback@nsc.com
Tel: 1-800-272-9959

www.national.com

National Semiconductor
Europe Customer Support Center
Fax: +49 (0) 180-530 85 86
Email: europa.support@nsc.com
Deutsch Tel: +49 (0) 69 9508 6208
English Tel: +44 (0) 870 24 0 2171
Français Tel: +33 (0) 1 41 91 8790

National Semiconductor
Asia Pacific Customer
Support Center
Email: ap.support@nsc.com

National Semiconductor
Japan Customer Support Center
Fax: 81-3-5639-7507
Email: jpn.feedback@nsc.com
Tel: 81-3-5639-7560